

SECTION 11110**TUMBLE DRYER, 170 LB. (77.1 KG) CAPACITY****PART 1 GENERAL**

1.01 SECTION INCLUDES:

- A. Automatic laundry dryer for processing water-washed linen items

1.02 SYSTEM DESCRIPTION

A. DESIGN REQUIREMENTS:

1. Dry weight capacity: 170 lb. (77.1 kg)
2. Cylinder volume: 49.7 cu ft (1407347 cu cm) minimum
3. Construction: Heavy duty embossed steel with e-coat and baked enamel powder paint
4. Input voltage: 208-240/60/3
5. Heat source: Gas, natural, 1 inch (25 mm) NPT
6. Overall width: 53-1/8 inches (1349 mm) nominal
7. Overall height: 94 inches (2388 mm) nominal
8. Overall depth: 66-1/8 inches (1679 mm) nominal
9. Exhaust size: 12 inch (305 mm)
10. Control system: Microprocessor touchpad control
11. Stainless steel door: High grade stainless steel door with 7/8 inch (22 mm) rubber gasket and heavy duty hinge

B. PERFORMANCE REQUIREMENTS:

1. BTU input: 395,000
2. Airflow: 2450 CFM (69.38 CMM)
3. Motor horsepower: 3 hp fan and 3/4 hp cylinder
4. Reversing cylinder
5. Control system
 - a. Programming methods: Machine keypad, Infrared (PC or PDA)
 - b. 41-Cycle Capability with graphic display of words and icons
 - c. PC software to program machine and/or audit machine performance with quick view performance reports
 - d. Record start, stop and idle time by date and time
 - e. Record last eight machine errors by date and time
 - f. Record machine service history
 - g. Internet connectivity for off-site diagnostic capabilities
 - h. Automatic maintenance reminders by day, week and month
 - i. Over Dry Prevention Technology (OPTidry™) system utilizes two cylinder lifters as sensors (note: some capacities only have one sensor lifter)
 - j. Maintenance-free rotary transfer switch communicates signal between OPTidry™ sensor/lifters and control

- k. Wrinkle free at cycle end allowing 30 seconds of tumble and 1-1/2 minutes of rest until door opens or maximum of one hour
- 6. Lint filter: 1653 sq. inch (10664 sq. cm), self cleaning, depositing lint to large storage area at bottom of tumbler

1.03 DELIVERY, STORAGE AND HANDLING

A. ACCEPTANCE AT SITE:

- 1. Inspect machine for damage prior to acceptance. If damage is found, follow freight handler's procedure for claims.

B. STORAGE AND PROTECTION

- 1. Machine should be stored in a site protected from weather, direct sunlight and temperature extremes. Do not remove packaging prior to storage.
- 2. If machine is to be stored for an extended period of time, consult manufacturer for special requirements.

1.04 WARRANTY

- A. Warranty Period: Three years, limited, parts only, commencing on Date of Substantial completion

1.05 SYSTEM STARTUP AND COMMISSIONING

- A. Machine installation should be inspected by local manufacturer's representative prior to startup and operation. The party installing the machine is responsible for setting the schedule for this inspection.

PART 2 PRODUCTS

2.01 MANUFACTURERS

- A. Alliance Laundry Systems LLC - UniMac, obtain commercial laundry equipment from a single manufacturer

2.02 QUALIFIED MODELS

- A. UniMac model **UT170NRU** (no substitutions permitted)

PART 3 EXECUTION

3.01 INSTALLATION

- A. Refer to and comply with manufacturer's installation instructions. Do not deviate without permission from site owner, architect, general contractor and manufacturer's local representative.

Machine Dimensions and Specifications

Models UT170L and UT170N



Dimensions

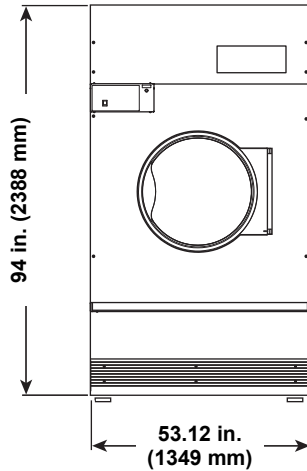

FRONT

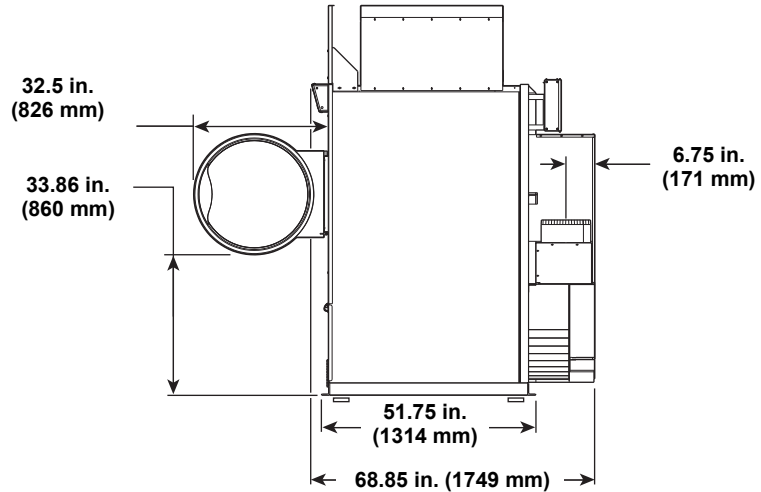

RIGHT SIDE

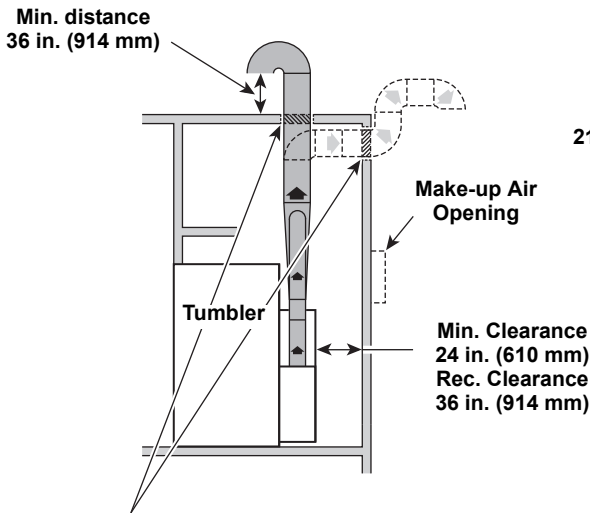

Min. clearance both sides of duct 2 in. (51 mm)

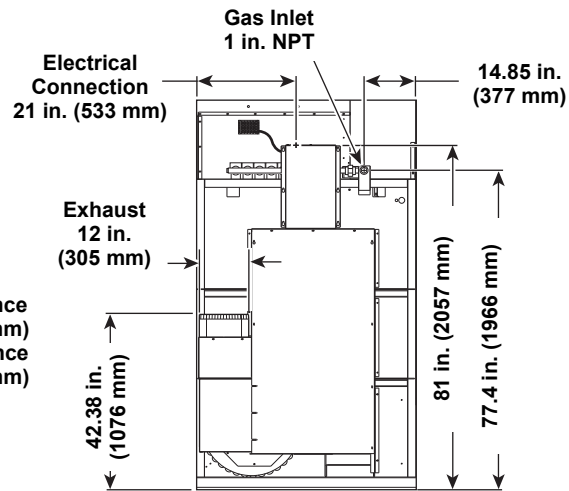

BACK

TMB52F

Specifications

Net Weight	1575 lbs.
Make-up Air Opening	525 sq. in.
Maximum Airflow per Pocket: C.F.M.	2450
Maximum Static Back Pressure: Inches W.C.	0.3
Gas Burner Rating:	395,000 Btu/hr

Electrical Specifications

Code	Voltage	Cycle	Phase	Wire	Full Load Amps	Breaker Rating (Amps)	Breaker Poles	AWG
F6	200-208, 240	60	3	3	13.5	20	3	12
Q1	460-480	60	3	3	6.7	15	3	14